



■ 不锈钢泵头

■ 铝合金连杆

KPDA-CF2 SERIES



适用范围 application

工业环卫水处理、海水淡化、石油、消防、管道疏通、船舶制造、煤矿行业等广泛应用

Widely used in industrial sanitation water treatment, seawater desalination, petroleum, firefighting, pipeline dredging, shipbuilding, coal mining industry, and other industries

外形尺寸 Dimension

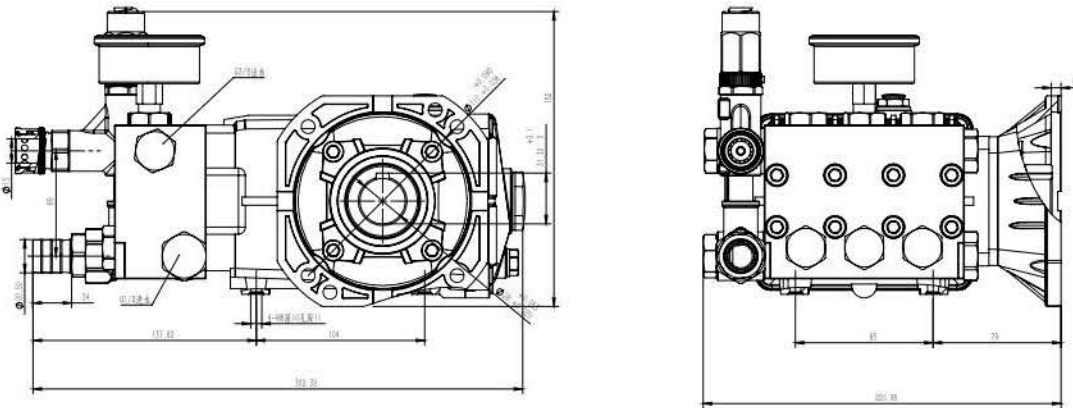

性能参数 Specification

产品型号 Model	流量 Flow		压力 Pressure		电机功率 Power		转速 Speed (R.P.M)	重量 Weight (kg)	进水口	出水口
	(L/min)	(gpm)	(bar)	(psi)	(hp)	(kw)			Water inlet	Water outlet
KPDA1810	11	2.90	100	1450	2.9	2.0	1450	10	φ19.5mm	外M22x1.5内14孔
KPDA1813	14	3.70	120	1740	4.5	3.0	1450	10	φ19.5mm	外M22x1.5内14孔
KPDA1814	15	3.96	150	2175	6.0	4.0	1450	10	φ19.5mm	外M22x1.5内14孔
KPDA1815	15	3.96	200	2900	8.0	5.4	1450	10	φ19.5mm	外M22x1.5内14孔
KPDA2010	15	3.96	250	3625	10.0	6.7	1450	10	φ19.5mm	外M22x1.5内14孔
KPDA2013	15	3.96	300	4350	12.1	8.0	1450	10	φ19.5mm	外M22x1.5内14孔
KPDA2014	17	4.49	150	2175	6.8	4.6	1450	10	φ19.5mm	外M22x1.5内14孔
KPDA2015	20	5.28	100	1450	5.4	3.6	1450	10	φ19.5mm	外M22x1.5内14孔
KPDA2016	20	5.28	300	4350	16.1	10.7	1450	10	φ19.5mm	外M22x1.5内14孔