

KPV SERIES



适用范围 application

工业环卫水处理、海水淡化、石油、消防、管道疏通、船舶制造、煤矿行业等广泛应用

Widely used in industrial sanitation water treatment, seawater desalination, petroleum, firefighting, pipeline dredging, shipbuilding, coal mining industry, and other industries

外形尺寸 Dimension

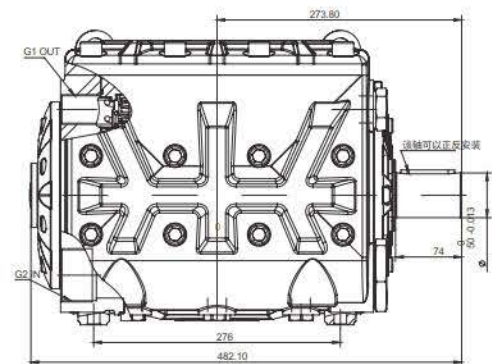
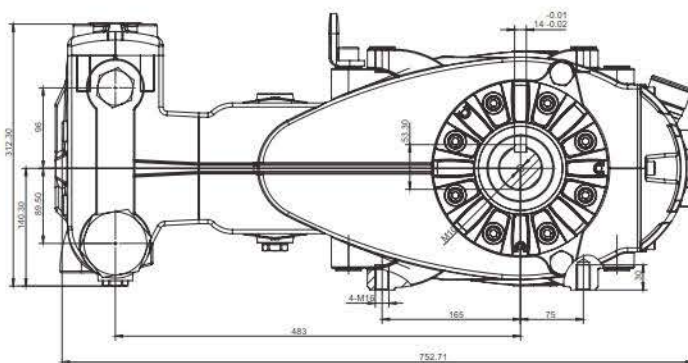

性能参数 Specification

产品型号 Model	流量 Flow		压力 Pressure		电机功率 Power		转速 Speed (R.P.M)	重量 Weight (kg)	进水口 Water inlet	出水口 Water outlet
	(L/min)	(gpm)	(bar)	(psi)	(hp)	(kw)				
KPV2870	135	34.3	300	4350	103	76	1000	215	2-G2"	2-G1"
KPV3270	169	44.3	250	3625	115	85	1000	215	2-G2"	2-G1"
KPV3670	214	56.2	200	2900	115	85	1000	215	2-G2"	2-G1"
KPV4070	263	69.4	160	2320	115	85	1000	215	2-G2"	2-G1"
KPV4570	335	87.9	125	1812	115	85	1000	215	2-G2"	2-G1"
KPV5070	412	108.8	105	1522	115	85	1000	215	2-G2"	2-G1"
KPV5570	505	131.5	85	1232	115	85	1000	215	2-G2"	2-G1"