

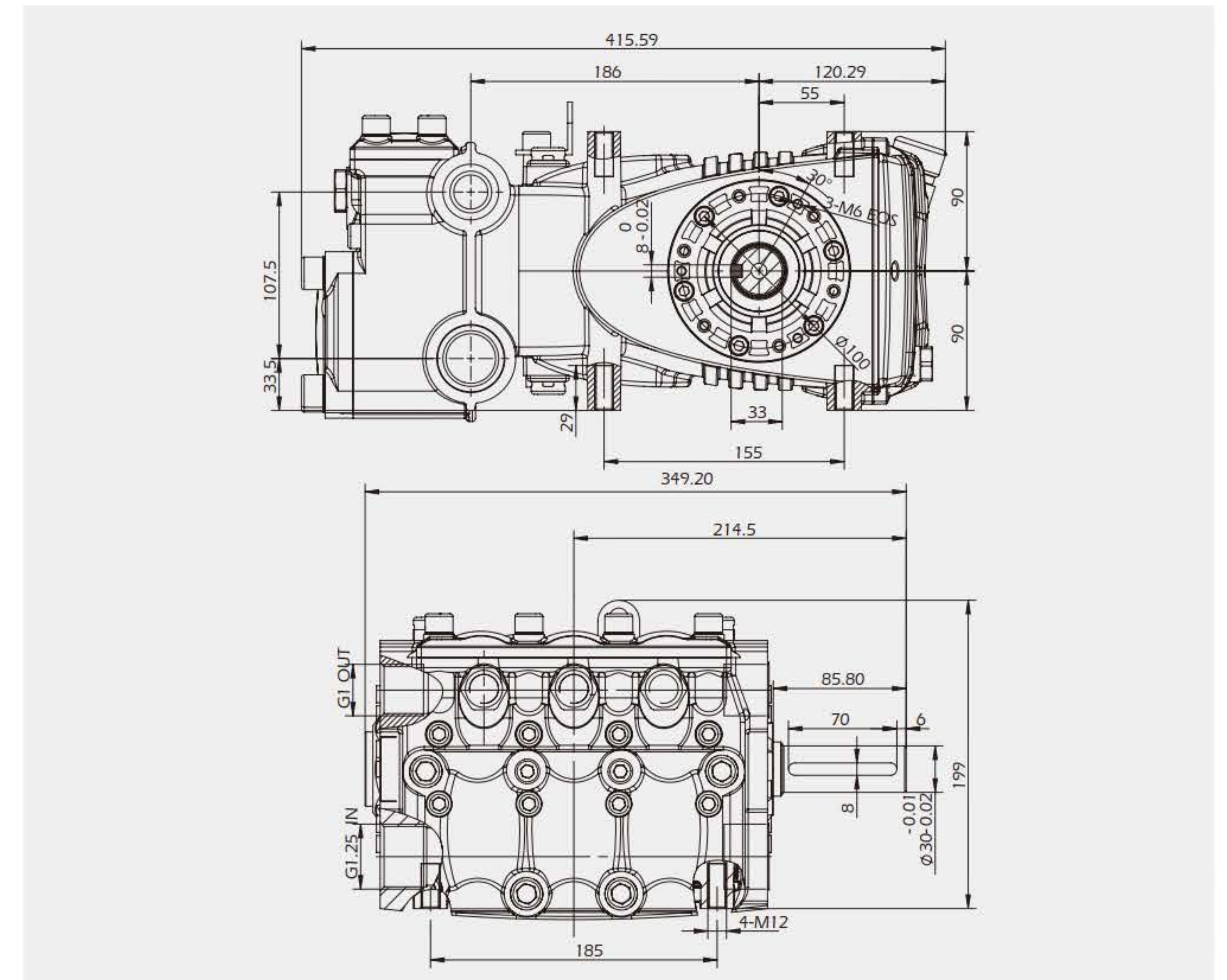

KPN SERIES

外形尺寸 Dimension



性能参数 Specification

产品型号 Model	流量 Flow		压力 Pressure			电机功率 Power		转速 Speed	重量 Weight
	(L/min)	(gpm)	(bar)	(psi)	(Mpa)	(hp)	(kw)	(R.P.M)	(kg)
KPN56/25	56	14.8	250	3625	25	37	27	1450	42
KPN70/20	70	18.4	200	2900	20	37	27	1450	42
KPN84/17.5	84	22.2	175	2538	17.5	38	28	1750	42
KPN80/17.5	80	21.1	175	2538	17.5	38	28	1450	42
KPN96/14	96	25.5	140	2030	14	37	27	1750	42
KPN91/15	91	24.0	150	2175	15	37	27	1450	42
KPN115/12	115	30.4	120	1740	12	38	28	1450	42
KPN139/10	139	36.7	100	1450	10	38	28	1750	42
KPN142/10	142	37.5	100	1450	10	38	28	1450	42
KPN124/10	124	32.8	100	1450	10	33	24	1000	42
KPN112/10	112	29.6	100	1450	10	30	22	900	42
KPN99/10	99	26.2	100	1450	10	27	20	800	42