

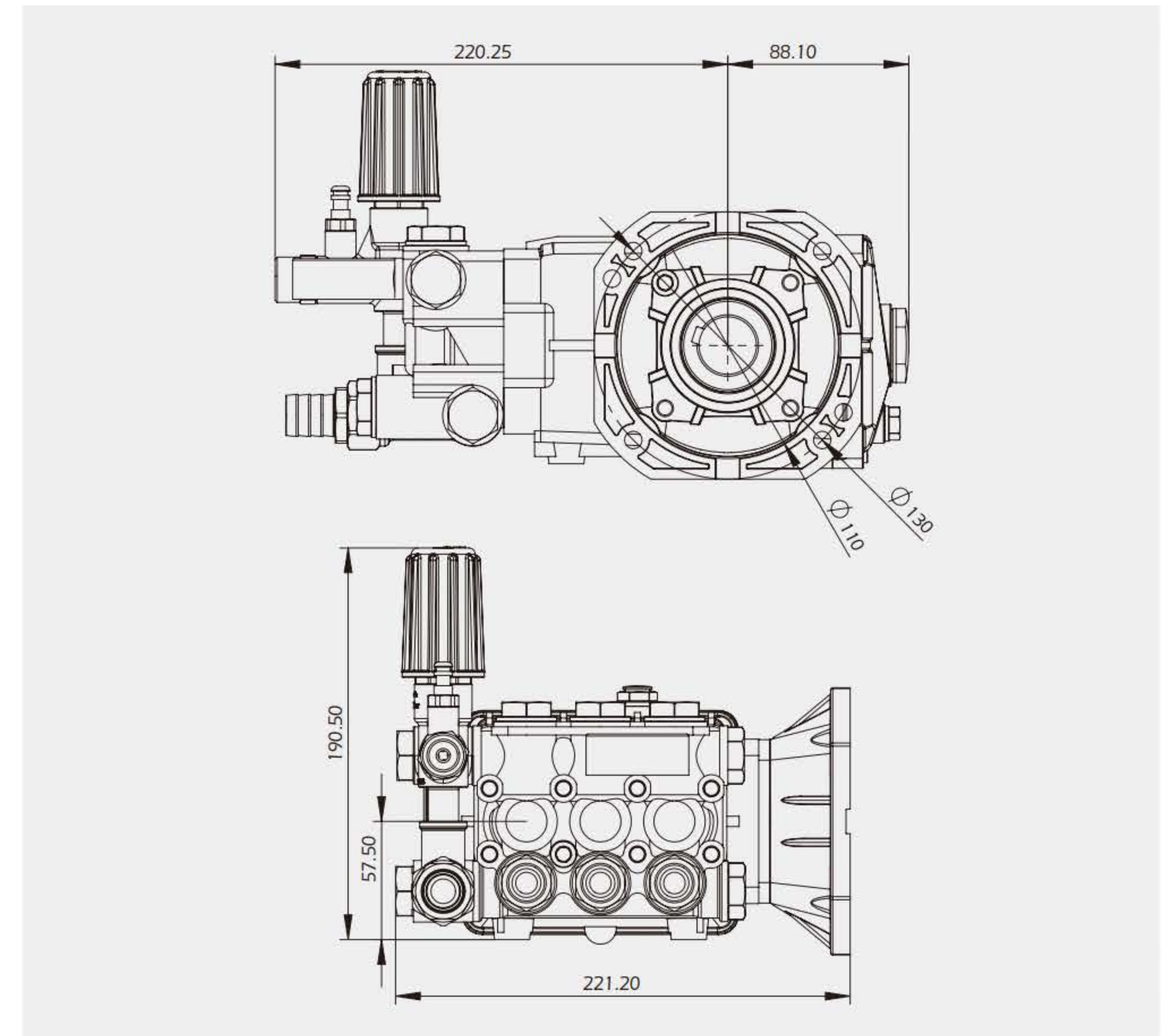

KPA-CF2 SERIES

外形尺寸 Dimension



性能参数 Specification

产品型号 Model	流量 Flow		压力 Pressure		电机功率 Power		转速 Speed	重量 Weight
	(L/min)	(gpm)	(bar)	(psi)	(hp)	(kw)	(R.P.M)	(kg)
KPA1110CF2	11	2.90	100	1450	2.9	2.0	1450	10
KPA1412CF2	14	3.70	120	1740	4.5	3.0	1450	10
KPA1515CF2	15	3.96	150	2175	6.0	4.0	1450	10
KPA1520CF2	15	3.96	200	2900	8.0	5.4	1450	10
KPA1525CF2	15	3.96	250	3625	10.0	6.7	1450	10
KPA1530CF2	15	3.96	300	4350	12.1	8.0	1450	10
KPA1715CF2	17	4.49	150	2175	6.8	4.6	1450	10
KPA2010CF2	20	5.28	100	1450	5.4	3.6	1450	10
KPA2030CF2	20	5.28	300	4350	16.1	10.7	1450	10